

TerraWave Solutions® MIMO Site Survey Battery Pack (Part # TW-SSBP-007) Instructions For Use

Standard Shipping Contents of the TW-SSBP-007:

- 1 qty Site Survey Battery Pack (Diagram 1)
- 1 qty Charger (Diagram 2)
- 1 qty RJ-45 Red (802.3af) POE Cable (Diagram 3)
- 1 qty 2' 56 Volt Power Cord (Diagram 4)
- 1 qty 20' 56 Volt Power Cord (Diagram 4)
- 1 qty Bag of mounting plate fastening screws

Diagram 1: Site Survey Battery Pack

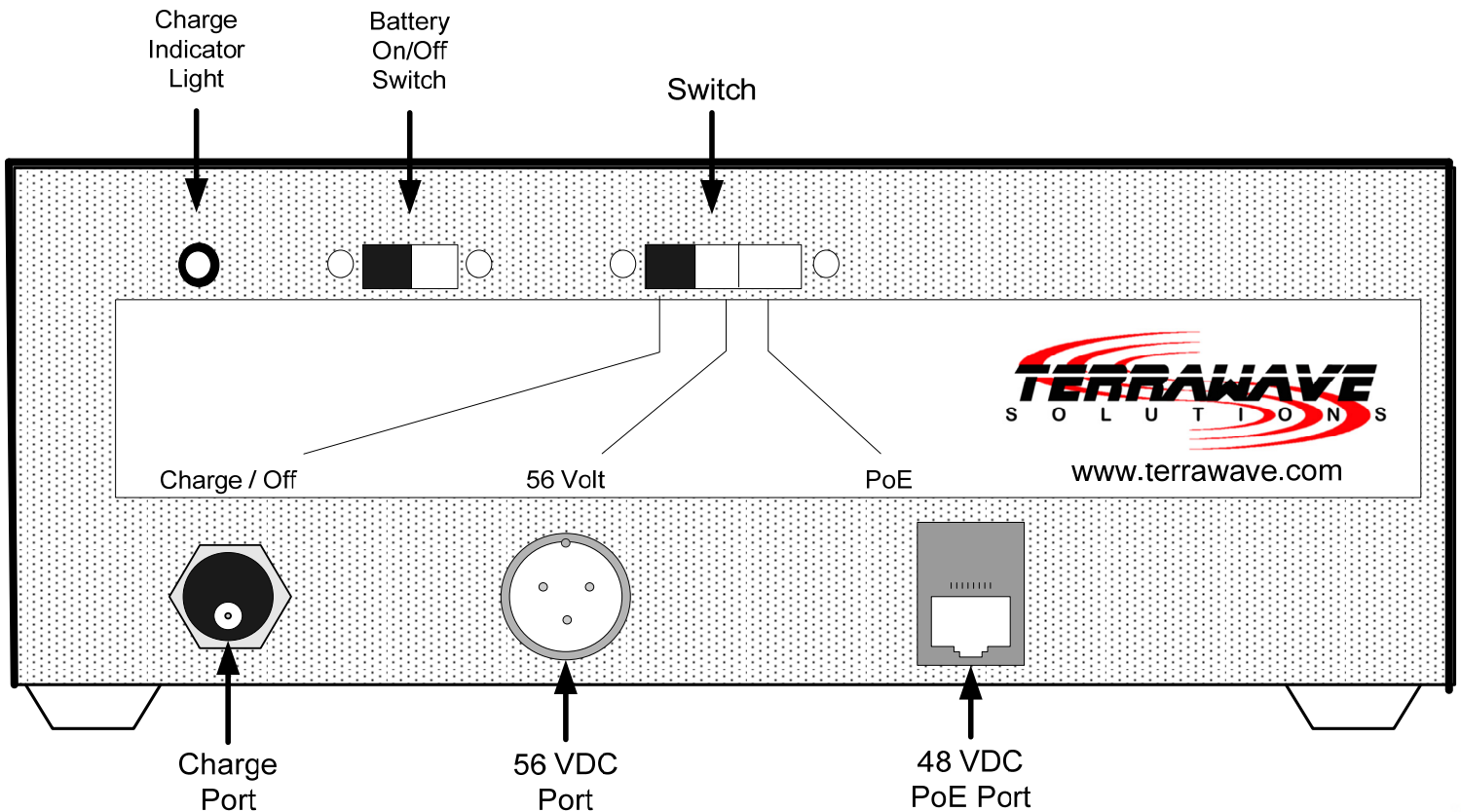

TerraWave Solutions® MIMO Site Survey Battery Pack (Part # TW-SSBP-007) Instructions For Use

Diagram 2: Charger



Diagram 3: RJ-45 Red (802.3af) POE Cable

This cable is intended for use for all access points that are 802.3af POE compliant.



TerraWave Solutions® MIMO Site Survey Battery Pack (Part # TW-SSBP-007) Instructions For Use

Diagram 4: 56v power cable w/barrel connector **AP1252**

This cable is intended for use with the Cisco AP1252.



Diagram 5: 56v power cable w/barrel connector **AP1252**

This cable is intended for use with the Cisco AP1252.



Diagram 6: 48v POE for patch cable

This cable is intended for use with 802.3af compliant Access Points only.

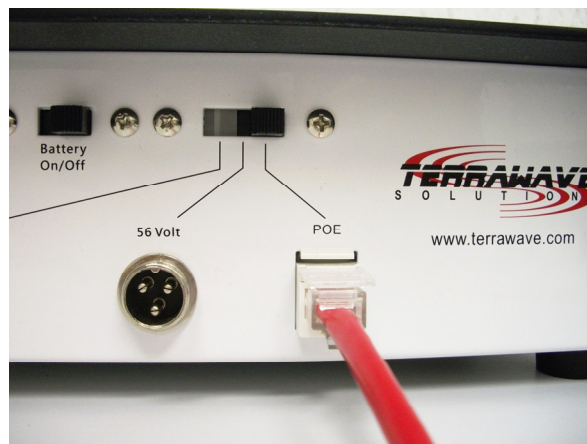

TerraWave Solutions® MIMO Site Survey Battery Pack (Part # TW-SSBP-007) Instructions For Use

Diagram 7: Access Point Mounting Holes on Lid of Site Survey Battery Pack

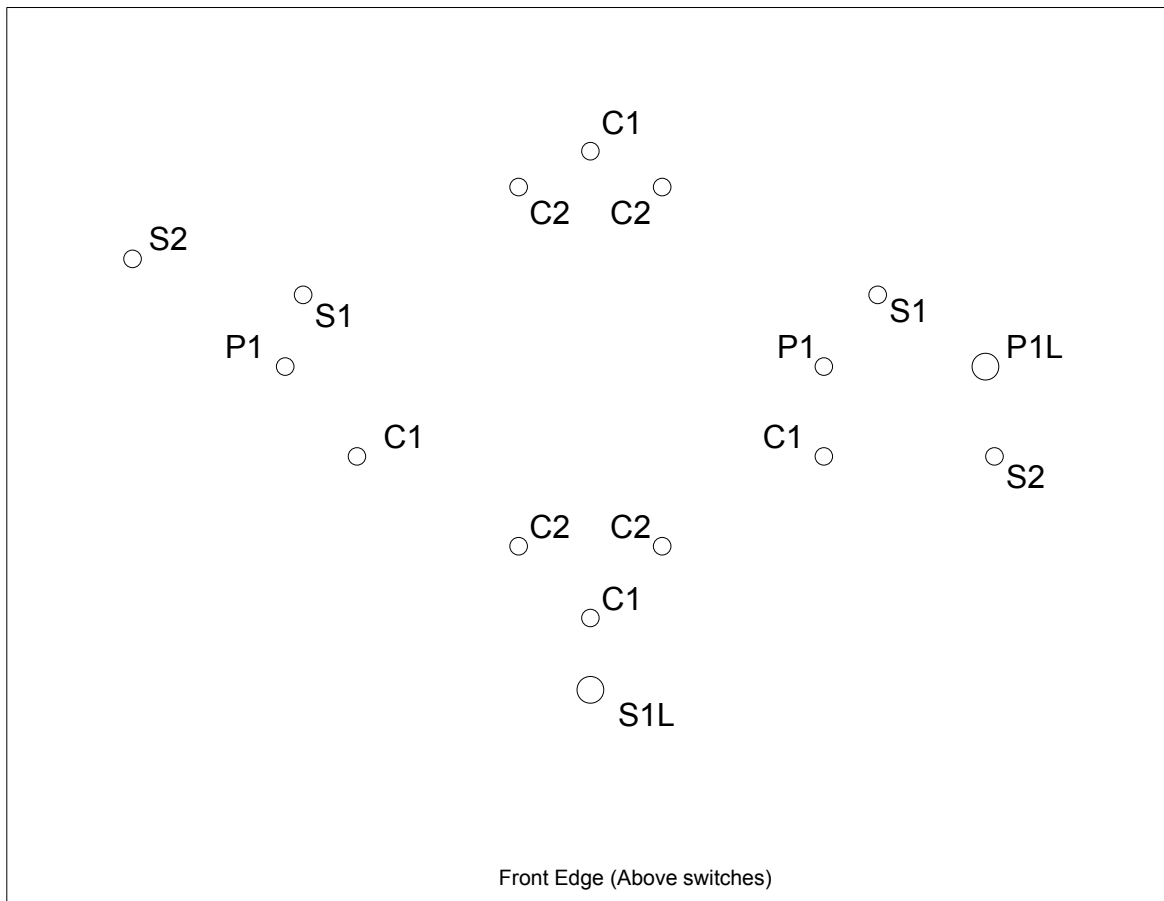

C1, C2, P1, S2 = 8-32 threaded

S1L, P1L = 10-32 threaded

S1 = 6-32 threaded

Hole Usage Chart:

<u>Hole</u>	<u>Screws to Use</u>	<u>Access Point</u>
C1	2 qty 8-32 Pan-head x 3/8" long	Cisco AP1142, AP124x and 125x ** Note - only 2 holes are needed – can use horizontal pair or vertical pair
C2	4 qty 8-32 Flat-head x 3/8" long	Cisco AP113x
S1	2 qty 6-32 Pan-head x 3/8" long	Symbol 4131
S1L	1 qty 10-32 Locking Post	To secure Symbol 4131
S2	2 qty 8-32 Pan-head x 3/8" long	Symbol 5131
P1	2 qty 8-32 Pan-head x 3/8" long	Proxim AP
P1L	1 qty 10-32 Locking Post	To secure Proxim AP



TerraWave Solutions® MIMO Site Survey Battery Pack (Part # TW-SSBP-007) Instructions For Use

Key Points to Understand:

1. Site Survey Battery Pack should power any access point or bridge for at least 6-8 hours given that the Site Survey Battery Pack has been fully charged.
2. The POE port is designed to power 48 Volt POE access points only.
3. When not in use, turn the switch (labeled Switch in Diagram 1) to the "Off / Charge" or LEFT position and the Master Battery On/Off switch to the "Off" or RIGHT position to switch the battery pack completely off. Do NOT store the battery pack in 56v or 48v switch positions. Also turning the Master Battery On/Off switch to the "Off" position will ensure that there is no drain on the battery and will help extend battery life.
4. The Charger (shown in Diagram 2) is designed to be international power capable. If it is going to be used outside of North America, then the appropriate adapter for that country should be used.
5. The Site Survey Battery Pack supports only 802.3af compliant access points and does *not* support the legacy Cisco power protocol solutions.

Disclaimer:

TerraWave Solutions is not liable for any damages to equipment, property or persons by the improper use of this Site Survey Battery Pack in any manner. It is imperative to know the proper use of this device.

Warranty:

The Site Survey Battery Pack and Charger are covered by a 6 month warranty. The warranty period starts from the date of purchase and does not cover damage to the unit from misuse, physical abuse or improper charging. Damages to the case are also not covered. TerraWave Solutions will replace the unit within the first month of purchase if it is deemed necessary. Within the six month warranty period, TerraWave Solutions will repair the unit if it is determined that the problem is caused by a manufacturer defect or malfunction.

Instructions for proper storage of the Site Survey Battery Pack:

The Site Survey Battery Pack utilizes a 12V sealed lead acid battery. Sealed lead acid batteries should not be stored on their side for a long period of time. The sealed lead acid battery inside the Site Survey Battery Pack is mounted on its side if the Site Survey Battery Pack is sitting on its rubber feet. While this is fine for days of use, *the Site Survey Battery Pack should be normally stored while sitting on its back side with all ports facing up to ensure the longest battery life.*



TerraWave Solutions® MIMO Site Survey Battery Pack (Part # TW-SSBP-007) Instructions For Use

Charging Instructions:

1. The Site Survey Battery Pack must be charged before each use. It is recommended to charge the Site Survey Battery Pack immediately upon receipt and before any expected use.
2. Turn the Master Battery On/Off switch to the "On" position for charging to commence.
3. Turn the switch (labeled Switch in Diagram 1) to the "Charge / Off" or LEFT position.
4. Plug the Charger (Diagram 2) into a proper AC power source.
5. Plug the barrel connector end of the Charger (shown in Diagram 2) to the Charge Port (shown in Diagram 1) of the Site Survey Battery Pack. Turn the Master Battery Pack On/Off switch to the "On" position and then the light on the battery pack should turn red, indicating that the battery is charging.
6. The Charge Indicator light will show the status of the Charging process. It should start out "Red", indicating that the battery is charging. It will then progress to "Green", indicating the battery is fully charged.
7. The Charger is designed to switch to maintenance charge cycle once the Site Survey Battery Pack has reached full charge (Green in color). Leaving the Charger connected longer will NOT harm the Site Survey Battery Pack.

Instructions for Use (802.3af Compliant Cisco 1252 Access Point):

There are two ways to power up a Cisco AP1252 – Described below:

A.) Important! The battery pack will support the 802.3af compliant Cisco AP 1252 for up to eight hours when using one radio at a time. There are two options to achieve this:

Power down the AP and physically remove the 2.4 GHz radio or the 5 GHz radio. The battery pack will support the remaining radio within the AP.

Turn off one radio within the AP. The battery pack will support the remaining active 2.4 GHz or 5 GHz radio.

To turn off a radio:

```
AP1252 (config) #interface dot11radio 0
```

```
AP1252 (config-if) #shutdown
```

To turn a radio back on:

```
AP1252(config) #interface dot11radio 0
```

```
AP1252(config-if) #no shutdown
```

Note: Here the 0 indicated the radio in slot 0, typically the 2.4 GHz radio. To control the 5 GHz radio (slot 1) substitute "1"

For use with the 802.3af compliant AP 1252 with both radios active and powered using 48 volts, please execute the following from a console session on the AP:

Configuration Instructions:

```
AP1252 (config) #power inline negotiation injector override
```



TerraWave Solutions® MIMO Site Survey Battery Pack (Part # TW-SSBP-007) Instructions For Use

CAUTION! The aforementioned instructions allow the use of both radios with the AP powered by the 48V PoE connection (see instructions below). This method is for site survey purposes only. **DO NOT use an AP in a production environment with these settings. Using this method in a production environment will likely cause damage to the AP and / or switch.**

B.) The battery pack will support the 802.3af compliant AP 1252 for up to 6 hours when using the 56v port and barrel connector (Diagram 4 & 5).

Attach the 2' or 20' adaptor / power cable to the battery pack by aligning the internal three prong connectors (Diagram 4 & 5).

Plug the right angle barrel connector into the power port on the Cisco AP 1252.

Slide the switch on the battery pack to the 56v position.

Slide Master Battery On/Off switch to the "On" position.

You should then see the Cisco AP 1252 begin to boot up.

Instructions for Use (All Other Access Points):

1. The Site Survey Battery Pack will allow access points and bridges to be mounted to the top of the Site Survey Battery Pack.
2. Before connecting the AP to the Site Survey Battery Pack, make sure that the Switch (labeled Switch in Diagram 1) is in the left or "Charge / Off" position and that the Master Battery On/Off switch is in the "Off" position.
3. The access point being powered and the power adapter cable being used will determine which of the powered ports that will be used. Each of the 2 powered ports has a unique connector that will only allow the proper adapter cable to be connected to the proper powered port. The 2 powered ports offer two different DC voltages. Only 1 of the 2 powered ports is live or powered at a time. It is dependent upon the positioning of the Switch (labeled Switch in Diagram 1). If you are trying to power a 56VDC access point, you must have the proper cable from TerraWave that plugs into the 56 Volt. The 56VDC port uses a 3-pin microphone connector on the Site Survey Battery Pack side of the adapter cable. The POE port will use a RJ-45 to RJ-45 cable to connect the Site Survey Battery Pack to the access point. These RJ-45 adapter cables are not standard patch cord or crossover pin-outs.
4. Make sure to use the appropriate TerraWave Solutions adapter cable for your AP. Plug the cable into the appropriate power port of the Site Survey Battery Pack and place the Switch (labeled Switch in Diagram 1) into the corresponding power setting position.
5. Plug the other end into the AP in the appropriate power port. For POE connected AP's, this will be the Ethernet port of the POE capable access point. NOTE: The battery pack will send a 48 Volt "test pulse" to ensure that the connected device can accept the 48 Volt power.
6. Now, verifying that all connections have been made properly, you should now see the AP start the boot up sequence. Once the boot up sequence is completed, you can start your Site Survey, assuming the AP is configured properly.